

PT-TD300 - Tapped Density and Apparent Density Testing Instrument

PT-TD300 is used to test the tapped (or “tamped”) density and apparent density of powders, granules, pigments and similar products in compliance with the current USP <616> methods 1 and methods 2 as well as with EP <2.9.34>, DIN EN ISO 787-11 and ASTM B527. The instrument automatically calculates the tapped density, Hausner flowability ratio and Carr compressibility index after each test and documents the results via the integrated protocol printer.

The bulk density of powders is usually reported both as "freely settled" and "tapped". The tapped density refers to the bulk density of the powder after a specified compaction process, usually involving tapping motion of the product cylinder.

The instrument can be used to derive additional physical product characteristics such as flowability and compressibility. Together these behavioral characteristics are used to maintain and improve product quality during development as well as securing product consistency in quality assurance and in-process control. The standard test cylinder volume is 250ml. Sets to test smaller volumes of 100, 50, 25 and 10ml are available as well.



The instrument automatically detects if the cylinder is inserted in the correct position

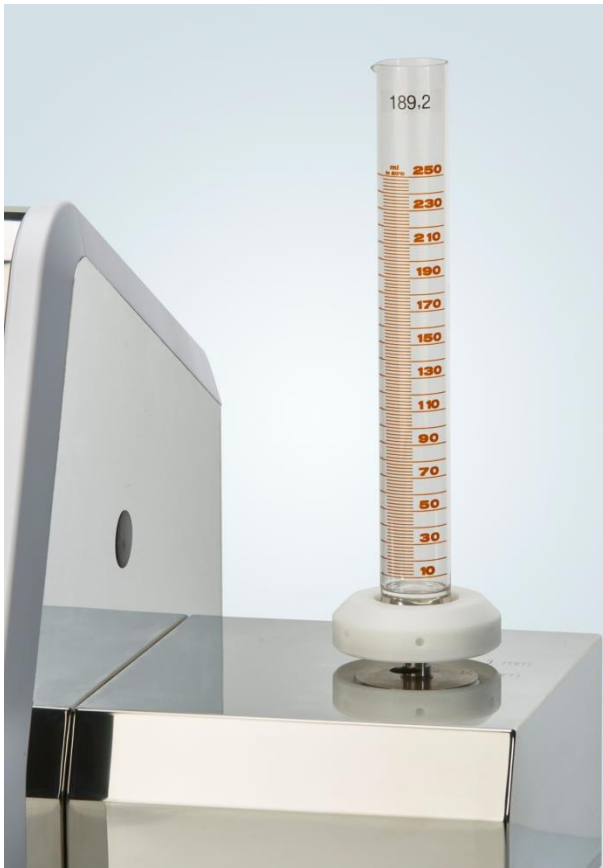

The instrument automatically detects the correct cylinder position

As per USP <616> the sample is initially tapped 10, 500, and 1250 times (strokes). The volume of the tapped sample is checked and another 1250 tap test follows. This procedure is repeated in case the volumes at 500 taps (V2) and 1250 taps (V3) differ by more than 2ml. This result is used to calculate the tapped density. The ability of the powder to settle is calculated as the difference between V1 and V2. Tapped density is expressed in g/ml and calculated as weight divided by volume. Furthermore the instrument automatically calculates the Hausner flowability ratio and Carr compressibility index. The Hausner ratio is used in a wide variety of industries as an indication of the flowability of a powder. It is related to the Carr index, which is an indication of the compressibility of a powder. According to these indices the results are evaluated (excellent > good > fair > passable > poor > very poor > very, very poor).

User Interface

PT-TD300 is operated by using a click wheel to navigate menus on the LC-display and by functional keys to shortcut frequent operations. The display is backlit in changing colors that show the instrument status in a familiar traffic light system (green, yellow, red). Navigating the menu is quick and simple. The color-changing display makes it easy for the user to see when his input is required to proceed.

The instrument has a method and a user management system. Methods can be programmed, edited and stored directly on the instrument. Users can be created and assigned different user levels according to their roles (administrator, operator, calibration technician).

Access to the instrument is protected by a login with username and password. Optionally a quick test menu can be accessed without logging in to the instrument first. This way tests can be performed with the instrument in case user access control and testing according to defined methods is not required.

A USB flash drive can be connected to the instrument to save and load methods in .csv-format. Print-outs can be stored as text files. Furthermore instrument firmware updates can be installed and factory settings be restored by using the flash drive without the need for any PC or programming tool.



Navigate the menus using a click wheel

Calibration

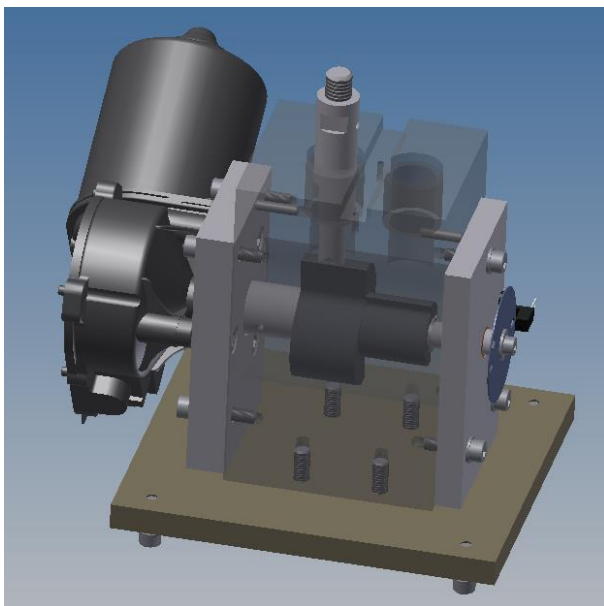

A double cam shaft provides the different tapping heights for method 1 and 2

PT-TD300 features dedicated calibration programs for tap number, tap height, tap frequency, weight measurement and timer function. The user is guided through each step of the calibration and a report is printed automatically. The reports are saved on the instrument and can be printed at a later time as well. A programmable qualification interval timer reminds the user to perform the instrument calibration once it is due. Each time the instrument is turned on it performs a quick self-check to ensure it is ready for operation. The result of the self-check can be documented via the integrated printer as well.



Example Print-Outs

PT-TD300 features an integrated protocol printer to document the test results and to print out calibration reports. An integrated printer saves valuable bench space in your laboratory.

<p>TEST REPORT - RUN TEST</p>	<p>Header including department, instrument serial number, date, time and user performing the test</p>
<p>Department: QC PT-TD300 SN: 20569 Version: 1.1 2017-01-05 10:30:29 User: ADMIN</p>	
<p>Product: CELLULOSE Batch: 1234ABCD Position: 14 mm</p>	<p>Descriptive information about the tested product, batch number and tapping height</p>
<p>Tap1: 10 Tap2: 500 Tap3: 1250 Initial Volume V0: 100 ml Weight m: 50,00 g</p>	<p>Programmed tap numbers, sample volume before tapping and sample weight (optional entry)</p>
<p>Results: V1: 95 ml V2: 91 ml Vf: 90 ml (V2-Vf = 1ml <= 2ml)</p>	<p>Sample volume after the tapping and criteria for ending the test</p>
<p>Statistics: Total Taps: 1760 Initial Density (m/V0): 0,50 g/ml Tapped Density (m/Vf): 0,56 g/ml Hausner Ratio (V0/Vf): 1,111 CI (100x[(V0-Vf)/V0]): 10%</p>	<p>Statistics including tapped density, Hausner ratio and Carr compressibility index</p>
<p>Result Evaluation: Hausner Ratio: Excellent CI: Excellent</p>	<p>Result evaluation according the Hausner and Carr compressibility (CI) indices</p>
<p>2017-01-05 10:31:02</p>	
<p>Operator Name:</p>	<p>Space for operator to enter his name and to sign the report</p>
<p>Signature:</p>	

Example Result Report Print-Out



Advantages

Some of the highlights the PT-TD300 offers are:

- Use a single instrument to test tapped density and apparent density according to both method 1 and method 2 from USP <616>
- Automated detection of correct cylinder position according to selected method
- Integrated protocol printer reduces bench space requirements
- Detailed result report including calculation of Hausner flowability ratio and Carr compressibility index
- Evaluation of the results according to Hausner and Carr compressibility indices
- Determine the sample weight to automatically calculate apparent and tapped density
- Programmable qualification interval timer reminds the user to perform instrument calibration
- Dedicated calibration programs including reports for tap number, tap height, tap frequency, weight measurement and timer function
- Copy methods between instruments by using a common USB flash drive
- Export test reports as text files
- IQ/OQ documents included free of charge



Use the integrated protocol printer to document results and print calibration reports

Features

The main features of the PT-TD300 are:

- Fully compliant to USP <616> methods 1 and methods 2 as well as with EP <2.9.34>, DIN EN ISO 787-11 and ASTM B527
- Determine tapped density and apparent density
- Connect a balance to determine the sample weight (optional, weight can be entered manually)
- Connect USB flash drive to copy methods, store test reports, install optional firmware updates and to restore factory settings
- Integrated protocol printer
- User management system
- Method management system



The instrument features USB, LAN and RS-232 interfaces



Standard Scope of Supply

The PT-TD300 comes ready to use with the following standard scope of supply:

- PT-TD300 instrument
- 250ml graduated glass cylinder and suitable adapter
- Comprehensive documentation folder including:
 - User manual
 - QC/DQ testing certificate
 - IQ documentation
 - OQ documentation
 - Conformity Declaration
 - CE/EMC Declaration
 - Instrument logbook



Options

In addition to the standard scope of supply Pharma Test offers a broad range of accessories and options including:

- Noise insulation bonnet (part no. 491-2100)
- 250ml graduated plastic cylinder (part no. 490-0491)
- 100ml graduated glass cylinder and suitable adapter set (part no. 490-0210)
- 50ml graduated glass cylinder and suitable adapter set (part no. 491-0350)
- 25ml graduated glass cylinder and suitable adapter set (part no. 491-0325)
- 10ml graduated glass cylinder and suitable adapter set (part no. 491-0310)

A Note on Hausner Ratio and Carr Index

Hausner ratio and Carr index are methods based on empirical data and not on scientific research. Their merit is therefore not universally agreed upon. For USP/EP recognized results of flowability Pharma Test offers the alternative PTG-S4 powder characterization instrument. To determine apparent density the PT-SV100 Scott volumeter is available.



Technical Data

Parameter	Specification
Supported Test Methods	USP <616> method 1 and method 2 (corresponds to requirements from EP <2.9.34> and DIN EN ISO 787-11:1995-10)
Number of Test Stations	One test station with two cylinder positions (one for each method), automated detection of correct position acc. to selected method
Stroke Height	Method 1: 14.0mm ±2.0mm Method 2: 3.0mm ±0.1mm
Stroke Frequency	Method 1: 300 strokes/minute ±5 strokes/minute Method 2: 250 strokes/minute ±5 strokes/minute
Number of Strokes	Programmable in three stages from 1 to 9999 each
Method Management	Up to 256 test descriptions (methods) can be stored on the instrument
User Management	Up to 32 users with selectable user right levels can be stored on the instrument
Display	LC-display with color-changing backlight
Keyboard	Keypad with function keys and click wheel
Interfaces	USB type A host port to USB type B device port to connect flash drives, for PC communication and firmware updates ¹ LAN port for PC communication ¹ RS-232 printer port for optional external printer ¹ RS-232 balance port
Instrument Housing	Polished stainless steel housing with plastic frame
Power	110/230 Volt, 50/60 Hz
Instrument Dimensions	Approx. 50cm x 50cm x 45cm (D x W x H)
Net Weight	Approx. 18kg
Certification	All components certified to USP / EP requirements
CE / EMC Certification	All CE / EMC Certification provided
Validation	All IQ & OQ documents included

We reserve the right to make technical changes without any prior notice.

¹ PC communication and external printer support to be added in future firmware update